

LASERMET ICS-7-OEM

INSTRUCTION MANUAL

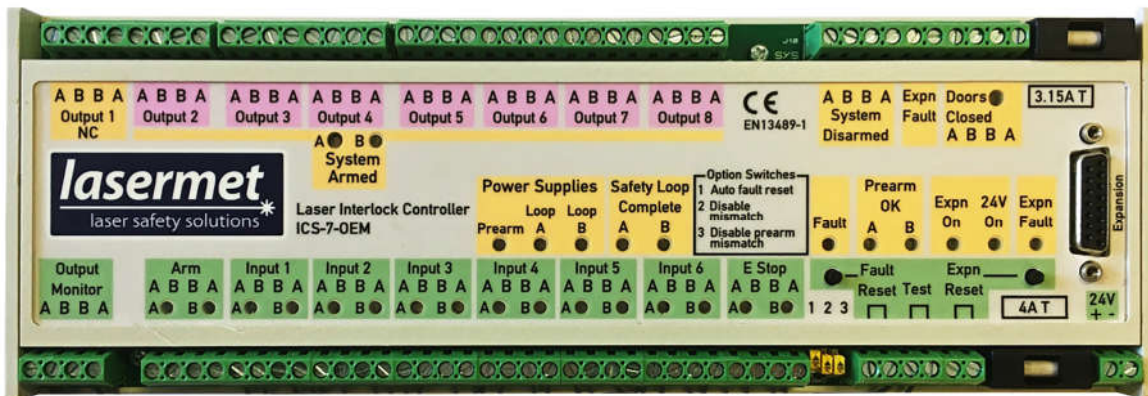

FAIL SAFE LASER INTERLOCK CONTROLLER

LASERMET ICS-7-OEM Instruction Manual

Contents

1	Declaration of Conformity	3
2	Safety Warnings.....	4
3	Concept.....	5
3.1	Differences between ICS-7-OEM and ICS-6-OEM	6
4	Summary of Evaluation of Compliance to EN ISO 13849-1:2015.....	7
5	Installation	8
5.1	Positioning.....	8
6	Wiring	10
6.1	ICS-7-OEM Inputs	11
6.2	ICS-7-OEM Illuminated Sign Control Output.....	14
6.3	Interlock Operator Output Contacts	15
7	Expansion Boards.....	20
7.1	Installing Expansion Boards.....	21
7.2	Use with Active Guarding.....	21
7.3	Expansion Board Fault Output	21
8	Mismatch Detector.....	22
8.1	Configurable Options for Safety Circuit Mismatch Events.....	22
8.2	Clearing a Mismatch Fault Indication.....	23
8.3	Mismatch Detector Remote Test and Reset	24
9	LED Indicators	24
10	Operation	26
10.1	Starting Up.....	26
10.2	Resuming Operation after an Interlock Switch has been opened	27
11	Fuses	27
12	Specifications	28
13	Warranty.....	28
14	Contact Details.....	29

1 Declaration of Conformity



LASERMET LIMITED

**INTERLOCK CONTROL PANEL ICS-7-OEM
Drawing Number 02058-00-000**

DECLARATION OF CONFORMITY

This is to certify that the ICS-7-OEM has been tested in accordance with the following directives and standards and found to comply.

Lasernet certifies that this product complies with the basic requirements for health and safety as provided by the following directives and standards:

Directives: Machinery Directive 2006/42/EC June 2010
Low Voltage Directive 2014/35/EU
EMC Directive 2014/30/EU

Standards: EN ISO 13849-1:2015
Safety of Machinery – Safety-related parts of Control Systems
EN 60947-1:2007 +A2:2014
Low Voltage Switchgear and Controlgear
EN 61010-1:2010 +A1:2016
Safety Requirements for Electrical Equipment

Supplier:

Lasernet Limited
Lasernet House
137 Hankinson Road
Bournemouth
BH9 1HR
Dorset
United Kingdom

Country of Origin: England

Signed.

Paul Tozer
Managing Director



Date: 31 July 2018



2 Safety Warnings

This device is intended to be used as part of a safety system which may be used to protect personnel and equipment from possible injury, damage, or loss.

As such it must be installed and wired according to these instructions and tested by suitably qualified persons. No attempt may be made to tamper with the parts, open them, or use them outside of the parameters contained herein.

The units are only designed to be fixed to surfaces using their inbuilt fixing holes. They must not come into contact with each other or any other moving part when in use. The parts should never be subject to impact or mechanical strain.

Safety switches should never be defeated or bypassed. It is imperative that all steps are taken to ensure that any spare actuators are made unavailable, such that they cannot be used to defeat the switch or reduce the protection offered by the system in any way.

Glossary

EN	European Normalised (Standard)
ICS	Interlock Control System
ISO	International Standards Organisation
LED	Light-Emitting Diode
NC	Normally Closed
NO	Normally Open
OEM	Other Equipment Manufacturer
PL	Performance Level
PLC	Programmable Logic Controller
SIL	Safety Integrity Level
V	Volts
VDC	Volts (Direct Current)

3 Concept

The ICS-7-OEM provides control of an interlock system primarily intended to protect persons from accidental exposure to hazardous lasers. It is able to monitor several doors, windows, curtains etc. fitted with safety interlock switches and disable the laser if any are open. In this manual the term 'Door Switch' refers to any interlock switch which may be fitted to a door, cover, window blind etc.

The versatile ICS-7-OEM system can be connected to any number of door switches and can indicate the status of up to 6 switches or groups of switches.

Two external volt-free contacts are required to arm the system. These might be from a PLC, for example. When these contacts are both closed, provided the necessary interlock input conditions are met (e.g. doors closed), the Controller will arm and enable the laser. If the Arm contacts are then opened the system will disarm.

If any interlock input (e.g. door) is open when the external Arm contacts are closed the controller will not arm. If the interlock is then closed the controller will still not arm. This is to prevent an unexpected start-up of the laser. If the system fails to arm because an interlock is open (e.g. door open), the Arm request should be removed and the interlock closed (e.g. close the door).

The ICS-7-OEM has a fully dual channel cross-checked architecture and when correctly wired can realise a system compliant with EN ISO 13849-1 up to performance level 'e'.

Eight safety interlock outputs each rated at 4A resistive, 50VDC, are provided to enable the laser, operate door locks, or provide signals to a PLC. The interlock outputs are volt-free contacts. Seven outputs close when the system is armed. The other output is normally closed and opens when armed. Each output actually comprises two contacts, one for each channel, operated by different relays. In the event of one contact failing to open, the other contact will open and the system is then disabled, preventing further use and maintaining safety. The contacts can be configured for a variety of options.

The ICS-7-OEM is able to directly control and monitor safety-rated power contactors which may be used to switch single or three-phase laser mains supplies.

The ICS-7-OEM is able to monitor output devices such as shutters with feedback (such as Lasermet's LS-20 and LS-200 beam shutters).

The controller has a pair of isolated volt-free contacts which close in the disarmed state provided all monitored devices are proven to be in the safe condition. These contacts may be used to operate the 'system disarmed' or 'laser off' section of a dual message illuminated sign. They are marked as 'System Disarmed' on the unit.

The controller also has a pair of contacts which close to indicate that all the interlock inputs are closed. This may be used, for example, to signal to a PLC that all doors are closed and is marked as 'Doors Closed' on the unit label.

The ICS-7-OEM has a mismatch detector which when wired to a full dual-channel system disables the system in the event of a mismatch between the two safety circuits. This provides protection against the single failure of a door switch etc.

The ICS-7-OEM can accommodate expansion modules externally, and Lasermet offer a range of modules including:

- Uncommitted Relays
- Active Guarding
- Safety Logic Plus
- Network Interface

Lasermet provides a full range of equipment including interlock switches, illuminated warning signs, laser shutters, entry keypads with built-in fail-safe override timer, door locks, external power supplies etc. which can be connected to the ICS-7-OEM to provide a complete system. Full support, design and installation is available from Lasermet, please contact us for any queries. Contact details are given at the end of this manual.

3.1 Differences between ICS-7-OEM and ICS-6-OEM

- Power supply to expansion modules is now switched on in the disarmed state, allowing visual checking of Active Guarding status before arming is attempted
- An extra normally closed interlock output has been added in addition to the 7 normally open outputs
- Fuses and option switches are now accessible without removing the top cover
- Electronic over-current trips are used instead of fuses for the A and B interlock supplies
- The case has been expanded to allow single rows of 5mm terminals
- An input/button has been added to reset faults latched on the Active Guarding expansion module
- An output has been added to indicate a fault on the expansion interface.
- All inputs and output connections are now in ABBA format

4 Summary of Evaluation of Compliance to EN ISO 13849-1:2015

To achieve a complete system performance level 'e' the system must be wired as described in this manual using suitably rated door sensors and measures taken to minimise the effects of common cause failures in the sensors and wiring which may be connected to the unit.

Achieved Characteristics:

Architecture	Category 4
Performance Level (PL)	PL = e
MTTFd	381 years
PFH [1/h]	2.47×10^{-8}
(Based on MTTFd being "capped" at 100 years)	
Mission Time	20 years
Diagnostic Coverage (DC)	99% (HIGH)

5 Installation

The ICS-7-OEM is designed to be attached to a 35mm 'top-hat' style DIN rail inside a control cabinet. It should always be enclosed in a cabinet that requires use of a tool or key to open to prevent tampering and risk of touching live connections.

Whilst the unit itself operates on 24V it is possible that higher voltages fed from other equipment may be present on its output contacts.

5.1 Positioning

The ICS-7-OEM should be mounted in a convenient position for wiring. It should be inaccessible by operators. It has indicator lights on its top surface which would normally only need to be observed by installation and maintenance personnel.

Provision should be made to prevent the unit from sliding along the DIN rail after fitting, for example by the use of end clamps or other equipment.

During installation, wired connections will need to be made from the ICS-7-OEM to all the interlocked doors, warning signs, laser interlocks, shutters, PLC and other equipment as required by the system. Allowance should be made for wire retention such as plastic slotted trunking running alongside both long sides of the unit.

All of the terminals are identified on the label on the top of the unit, see next page.

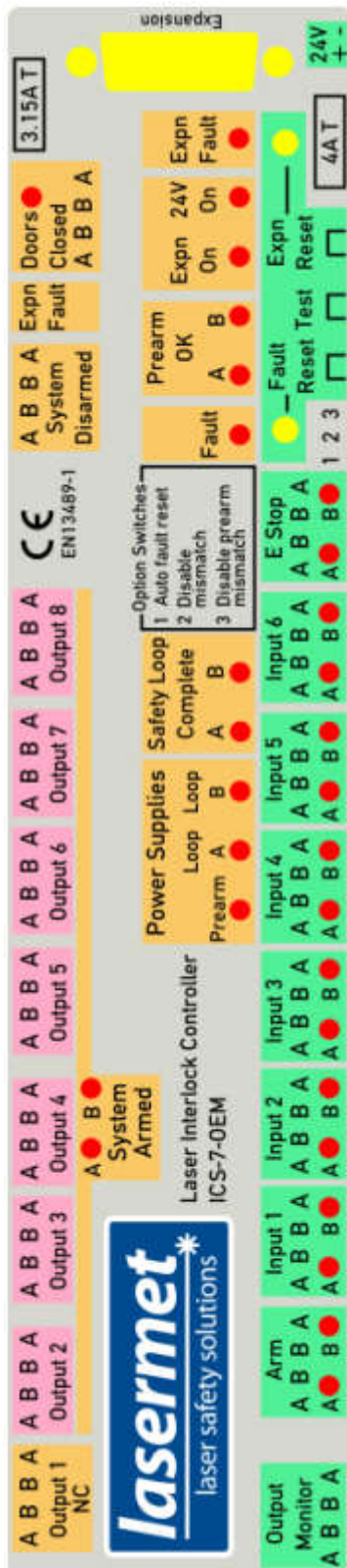

Figure 1: ICS-7-OEM Top Label showing terminal identification.

NOTE: Holes in the label are shown in yellow and windows for LEDs are shown in red

The indicator LEDs show the position of the interlock and arm input signals and the state of the controller.

All dual-channel inputs and outputs are wired ABBA, with one channel connected A-A and the other channel B-B.

Input signals are connected on the right (bottom) of the controller and are indicated by a green background.

All output signals are connected on the left (top) of the controller.

The normally open interlock operator outputs 2-8 are indicated by a pink background. The normally closed output 1 is indicated by an orange background.

Status outputs and status indications are indicated by an orange background.

6 Wiring

The ICS-7-OEM is a versatile interlock system and there are a variety of ways in which it can be used. Be sure you know which configuration you require before you attempt to wire the unit. If you require further assistance, please call Lasermet technical help. Contact details are at the end of this manual.

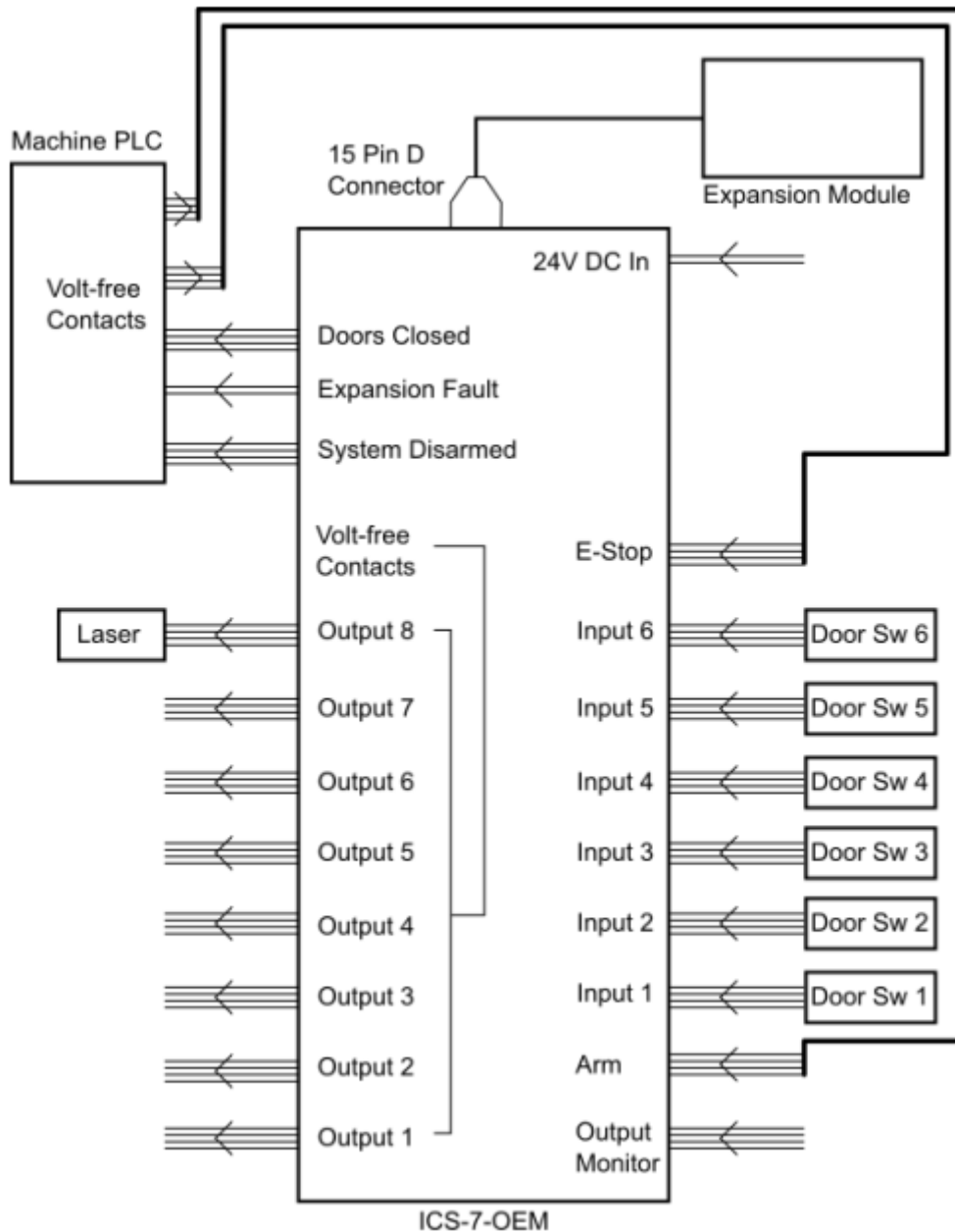

Example overall wiring scheme

6.1 ICS-7-OEM Inputs

Mechanical Interlock Switches

Up to six dual-channel door/cover interlock switches may be directly wired to the ICS-7-OEM. By making external connections, more switches can be added and arranged in groups.

The interlock switches are wired to the terminals labelled Input 1 through to Input 6. Each interlock switch should have two safety contacts which are closed when the door is closed. Some door contacts such as Lasermet’s IS-MECH switches have an additional monitor contact which closes when the door is opened. This is not used in ICS-7-OEM.

A 4-way terminal block is provided for each door interlock switch. One of the safety contacts which are closed when the door is closed is wired to the ‘A’ terminals. The other safety contact is wired to the ‘B’ terminals.

The example diagram below shows a system with two doors wired for ISO 13849 performance level ‘e’. Each door has two switches.

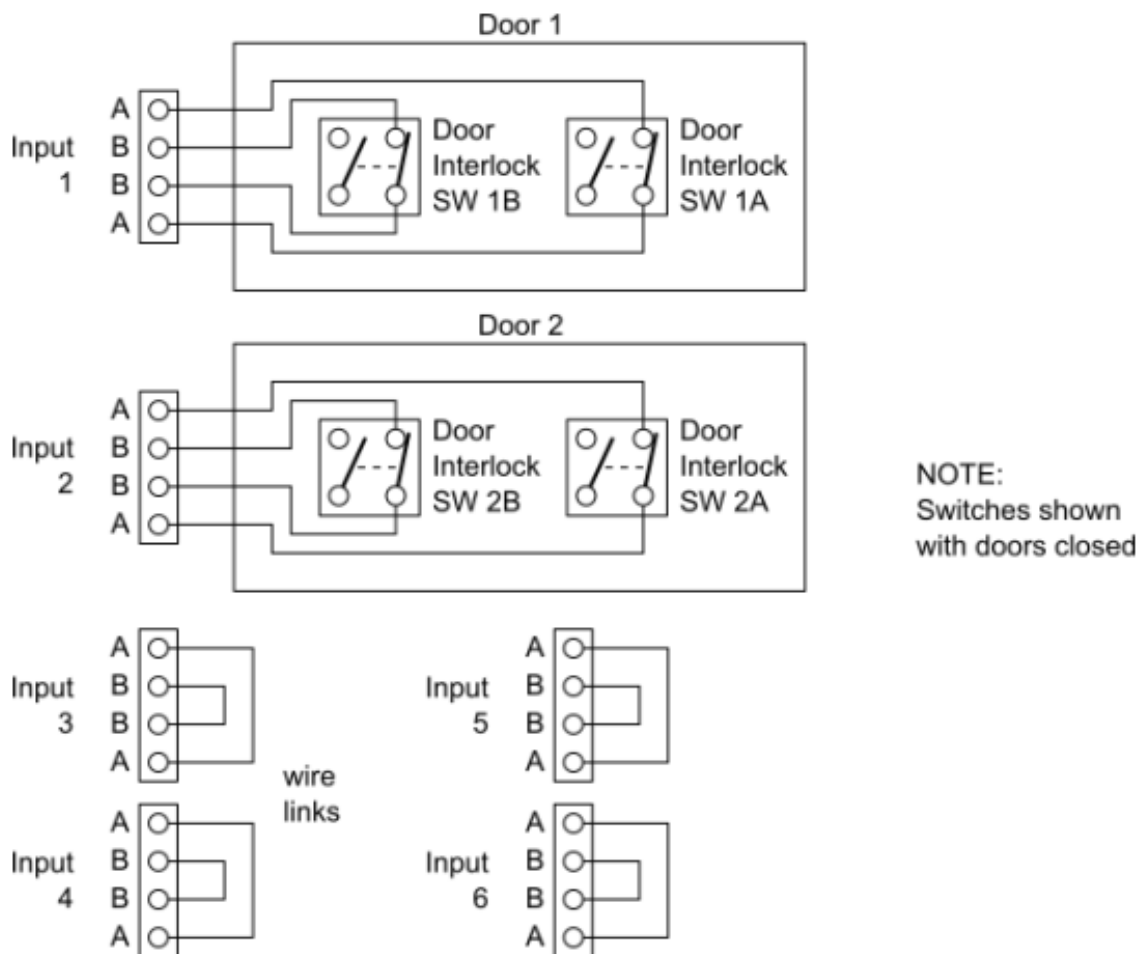

Wiring for two doors

If the system is required to perform to ISO 13849 performance level 'e', two switches are usually required to be fitted to each door, with the safety contact of one switch wired to the 'A' terminals and the safety contact from the second switch wired in a separate cable to the 'B' terminals. If there is any possibility of both cables being damaged for the same reason simultaneously it may also be necessary to route the cables in different paths.

If an Interlock input is not used, one wire link should be fitted to connect the 'A' terminals together, and a second wire link to connect the 'B' terminals on each unused input connector such as shown in the above example for inputs 3-6.

If the laser hazard is considered low, it is possible to use switches with only one safety contact. In this case connect the switch across the 'A' terminals. Fit a wire link across the 'B' terminals. The Mismatch Detector cannot be used and must be disabled, see the Mismatch Detector section below.

It is usual to use low voltage 4-core flexible cable for these connections and Lasermet can supply suitable cable in standard PVC or low smoke zero halogen (LSZH) types.

If there are more than six doors they can be wired in groups. A common situation is where there are double doors. Interlock switches need to be fitted to both, and the two doors can then be wired together so that a single pair of monitor indication lights will illuminate on the front panel of the ICS-7-OEM if either of the doors is open. The switches in a group should be wired with their safety contacts in series. Each group may have several switches. An example diagram for two door interlock switches wired in a group is shown below.

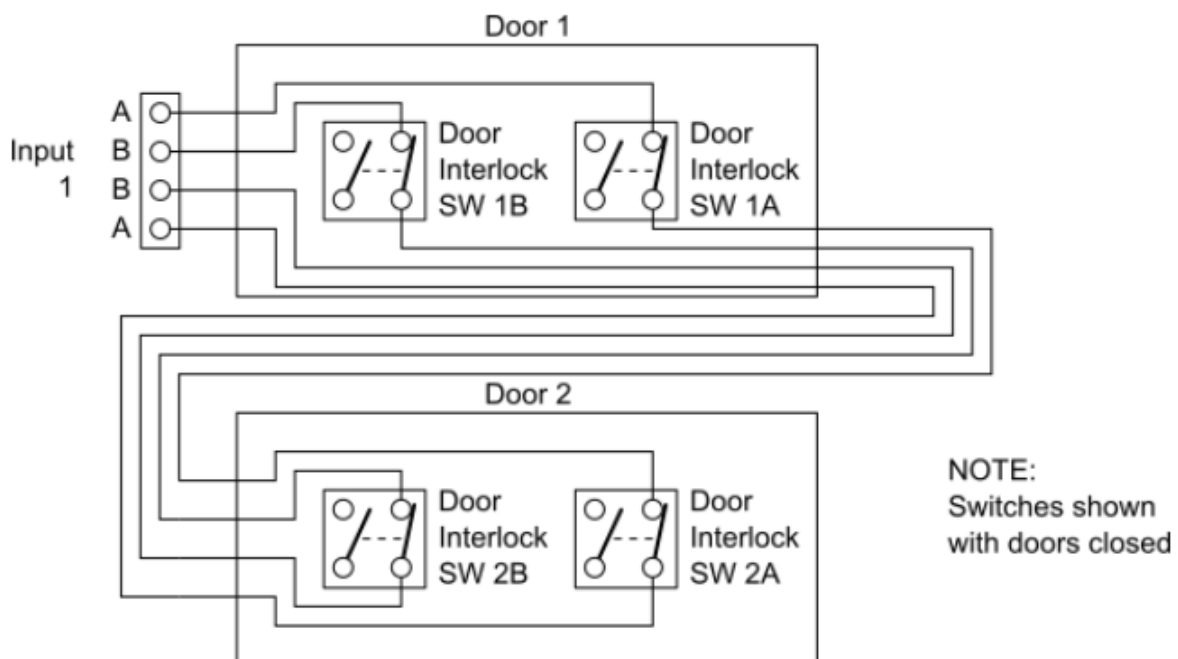

Coded Magnetic Interlock Switches

Coded magnetic switches supplied by Lasermet cannot be overridden by the use of a magnet. Wire the safety circuits in the same way as described in the 'Mechanical Interlock Switches section. The monitor contacts should not be used.

The Lasernetmet IS-MDC-12 is a dual channel magnetic door switch. If the mismatch detector is used in the ICS-7-OEM, any single contact failure in the door switch will be detected and the laser inhibited. In this switch the red and blue wires are taken to the 'A' terminals and the black and white wires to the 'B' terminals. The green and yellow wires are not used.

For the highest level of safety two separate door switches may be used, one wired to the 'A' terminals and one to the 'B' terminals.

Emergency Stop and Break Glass Switches

The ICS-7-OEM treats Emergency Stop switches in the same way as Door Interlock switches. Ideally the Emergency Stop switch should have two contacts which open when the button is pressed (2NC).

Connect one safety contact, which opens when the button is pressed, to the 'A' terminals of the E STOP terminal block. Connect the other safety contact to the 'B' terminals.

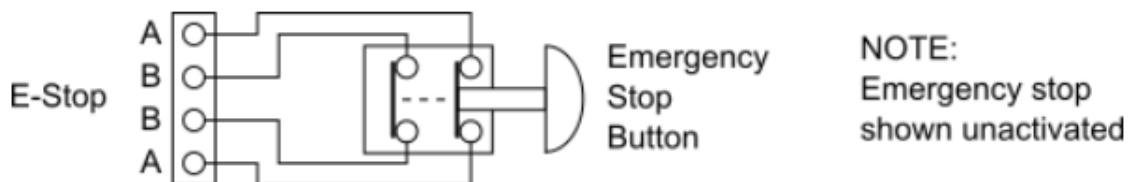

If there are two or more switches, connect the contacts in series as shown below.

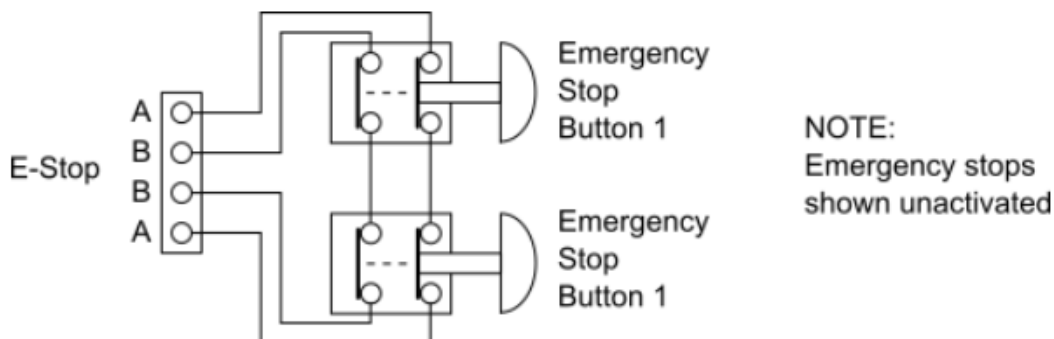

The Emergency Stop input may be driven by volt-free isolated contacts from a PLC or safety relay if desired. The contacts must both be closed for the system to operate and they should be arranged to operate simultaneously to avoid being detected as mismatched by the ICS-7-OEM.

If an emergency stop is not used, a wire link must be fitted between the two 'A' terminals on the E STOP terminal block, and a second wire link across the 'B' terminals.

NOTE: The E-stop switch should be checked periodically.

ICS-LJM and ICS-LJM-SO

When the ICS-LJM or ICS-LJM-SO is used with the ICS-7-OEM, the output from the LJM must go into the Emergency Stop input on the ICS-7-OEM.

6.2 ICS-7-OEM Illuminated Sign Control Output

Low Voltage DC Warning Signs

The following options are for 24VDC warning signs such as Lasernet's Miniature and Ultra Warning Signs. These signs must not be connected to the mains supply.

Option 1: One Way Illuminated Sign

The warning sign will come on when the controller is armed. One of the seven normally open outputs of the ICS-7-OEM is used to illuminate the sign. This output must not then be used to operate a laser interlock as well.

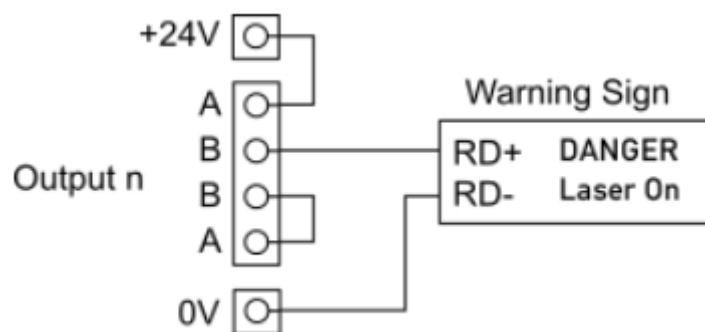

Option 2: Two way Illuminated Warning Sign

The 'Laser Off' warning sign will come on when power is applied to the ICS-7-OEM. This will go off and the 'Laser On' warning sign will come on when the controller is armed. Note that in the case of the Lasernet Miniature Warning Sign, both indications are displayed in the same unit.

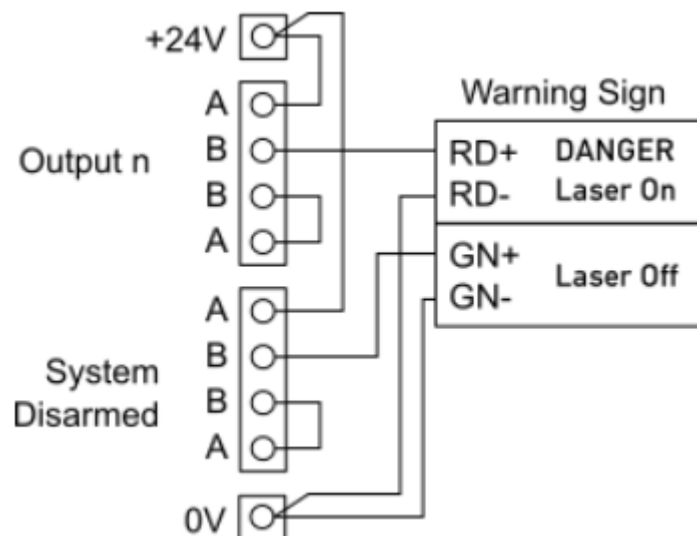

Note that the contacts inside the ICS-7-OEM are rated at 4A maximum and this rating must not be exceeded.

Note regarding Sign Operation

If output devices such as LS-20 shutters or contactors are fitted, or if the laser has feedback contacts which close to prove that it is in a safe condition and the feedback signal from such devices is taken to the 'Output Monitor' terminals of the ICS-7- OEM, the sign green 'Laser Off' indication will not be given if these devices are not proven to be in the safe condition or if they are removed from the system.

6.3 Interlock Operator Output Contacts

The ICS-7-OEM has seven dual-channel volt-free interlock operator output contacts (outputs 2-8) which may be used for various purposes including:

- Operating warning signs as shown above
- Controlling beam shutters
- Operating the laser's interlock input
- Controlling door locks
- Signalling the state of the controller to a PLC

There is also one normally closed output which opens when the laser is armed (output 1). This may be used for signs or for signalling the output state.

Beam Shutters

The ICS-7-OEM may operate one or more beam shutters and one or more laser interlocks. For permanent fixed installations these may be directly wired to the ICS-7-OEM. Where there is any possibility of the equipment being changed or moved it is often most convenient to be able to unplug the equipment.

Lasermet provide a range of small distribution boxes which allow for convenient positioning of wall or surface-mounted plugs for laser interlocks and sockets for shutters. The boxes are available with different combinations of plugs and sockets.

Modern industrial lasers are usually equipped with dual channel interlock inputs which may be directly connected to one of the dual channel outputs of the ICS-7-OEM as described later in this manual.

Many smaller lasers only have a single channel interlock input which can present problems if the safety system has to comply with ISO 13849 performance level 'e' since two methods of control are usually required. Some lasers have internal beam shutters which may be controlled by the ICS-7-OEM. If the laser has two means of disabling, e.g. interlock and internal shutter, it is recommended that both are used. Otherwise it may be necessary to consider having an external shutter in addition to the laser's own interlock if a high safety integrity is required.

Lasermet's beam shutters are supplied with suitable leads to plug into the distribution boxes. Open-ended leads are provided for laser interlocks allowing the customer to fit the correct plug for their laser.

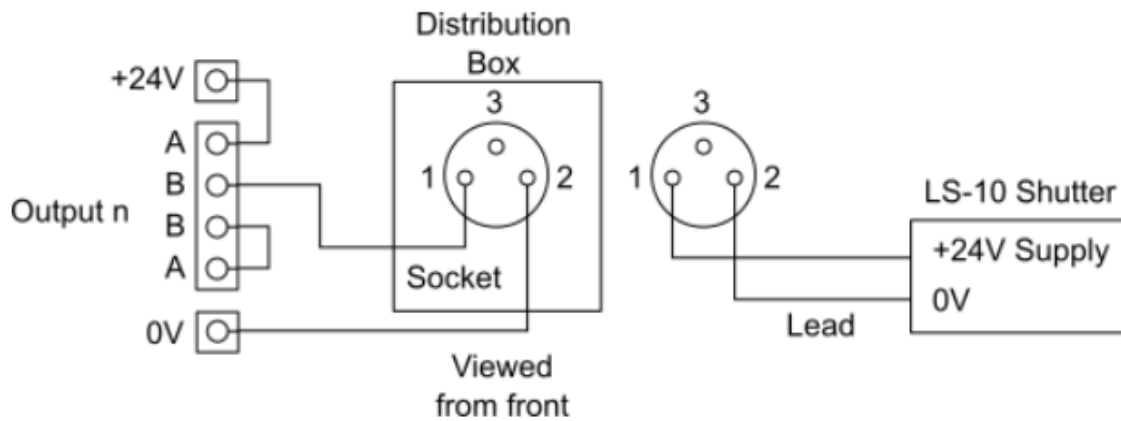

LS-10 Shutter

Use the above circuit. Note that old versions of LS-10 will only work off 12VDC.

LS-20 and LS-200 Shutter

The LS-20 and LS-200 Shutters can use the above circuit; however, it is recommended that the monitoring circuit shown below is included to allow the ICS-7-OEM to monitor the shutter and to detect any faults.

If using the LS-20 SIL3 twin shutter the circuit below must be used to achieve the SIL3 / PL 'e' rating.

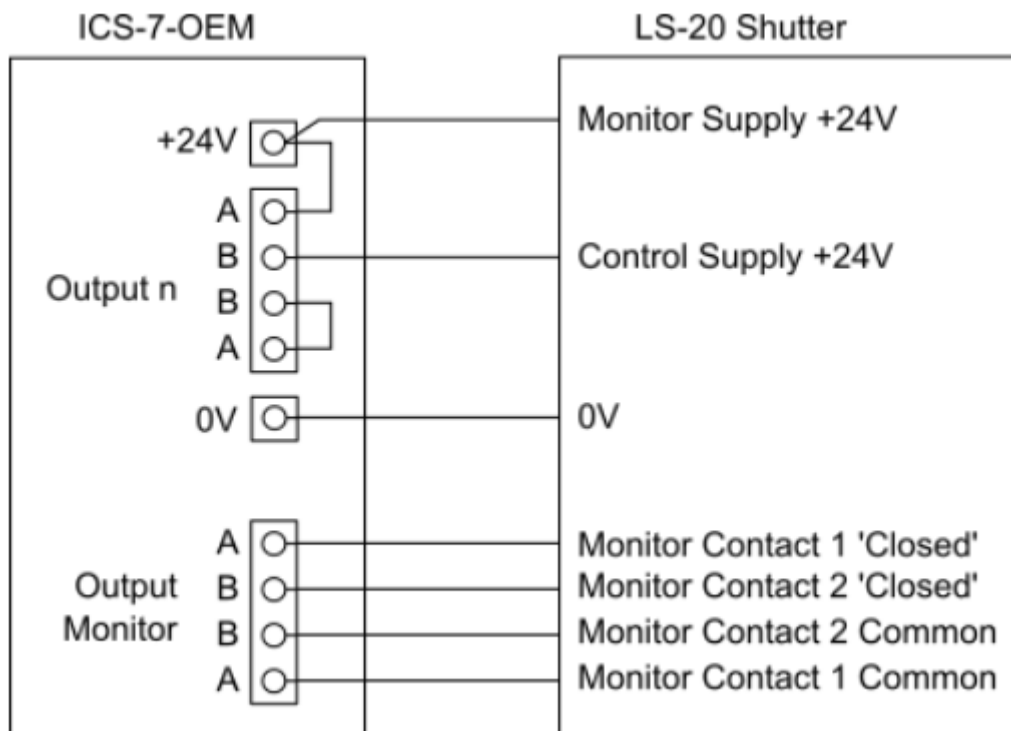

The LS-20 Shutter has its own distribution socket. The wiring connections inside the distribution box are shown below:

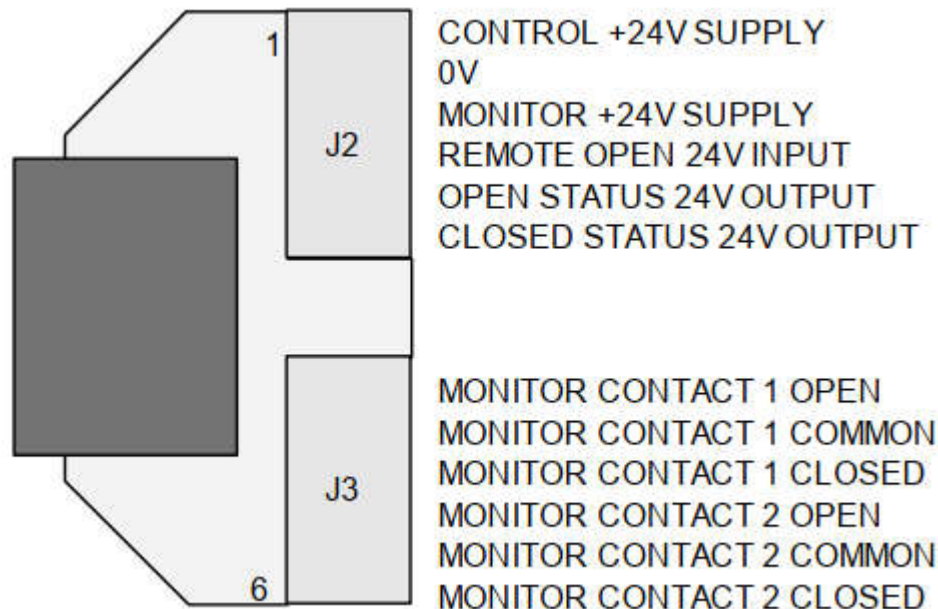

Shutter with own Power Supply

If your shutters have their own power supply or are to be run from an existing supply, you can use one of the controller outputs to operate them. If the shutter requires a single contact to operate it, connect the A and B contacts of the controller output in series as shown in the wiring diagrams above for LS shutters, so that the shutter closes if either one or both output contacts open.

The connections should be arranged so that the shutter closes when the Interlock Operator contact opens. Any ICS-7-OEM output used for shutters must not also be used for laser interlock control.

The contact is limited to 4A resistive load. If your shutter is solenoid-based it may need a protection diode fitted to prevent possible damage to the ICS-7-OEM.

Interlock Connectors

Any of the ICS-7-OEM output contacts may be used to operate a laser's interlock control, provided they haven't been used for any other purpose. The contacts are closed when the ICS-7-OEM is armed. If there is more than one laser each must use its own output connector on the ICS-7-OEM. Interlock sockets of several lasers must not be connected together.

Where the controller is part of a fixed laser system it is usual to directly connect the two devices. For lasers with a single interlock channel use the following connections:



For lasers with dual channel interlocks, use the following connections:

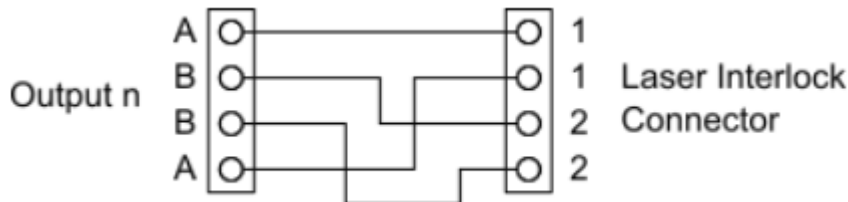

Where the laser may be removed from the system or exchanged a Lasermet Distribution Box may be used to provide a connection point convenient to the laser. In this case for lasers with a single channel interlock the A and B ICS-7-OEM output channels are connected in series to pins 1 and 2 of the plug of the distribution box. See the diagram below.

Leads are available in various lengths to plug into the distribution box. The other end of the lead is unconnected to allow fitting of a plug suitable for the laser.

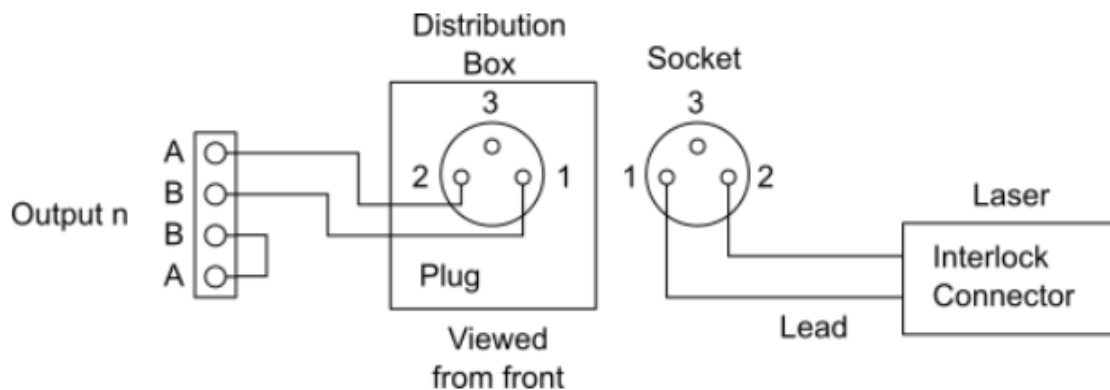

Most industrial lasers are now designed to be compliant with EN 13849-1 and feature two interlock input channels. This will require a distribution plug and socket with more connections. Furthermore, some lasers also include one or two 'laser safe' contacts which can be monitored by the ICS-7-OEM. In this instance if either or both 'laser safe' contacts are not closed the ICS-7-OEM will not illuminate the 'Laser Off' section of any such warning sign and arming will be inhibited. Depending on the safety performance of the laser itself such a system could meet EN 13849-1 performance level 'e'.

The wiring of such a laser is shown below. Please contact Lasermet for assistance with distribution boxes, connectors and leads if required.

If other devices are using the Output Monitor terminals, for example an LS-20 shutter, all the safe proving contacts for each channel should be wired in series to the Output Monitor connector such that the circuit is complete when all devices are in the safe condition.

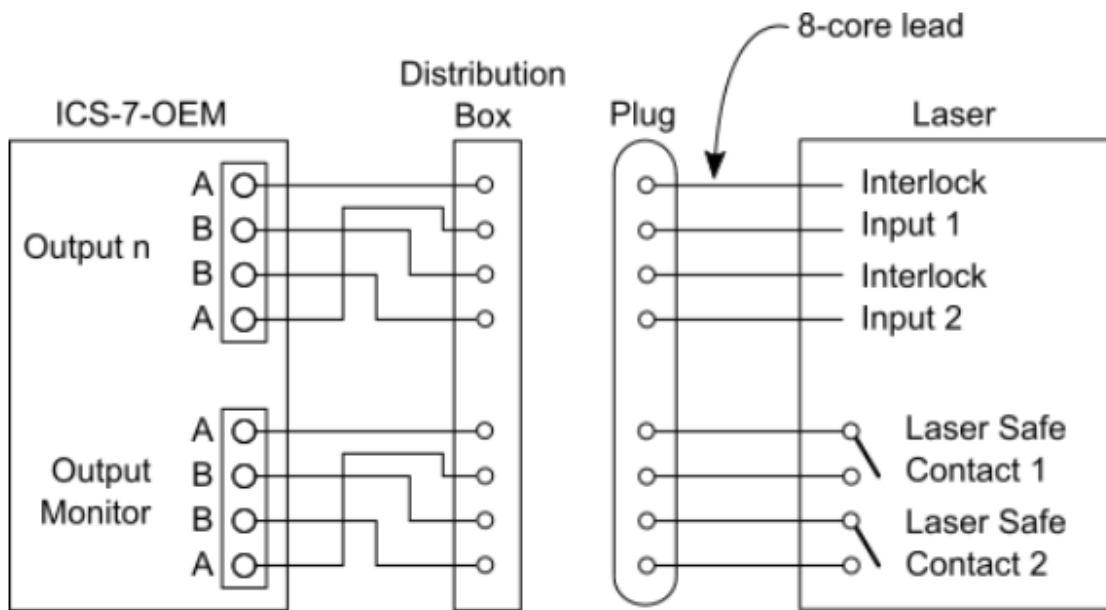

If the Output Monitor terminals are unused a wire link must be fitted between the 'A' terminals, and a second link between the 'B' terminals.

Electro-magnetic Door Locks

Use only fail safe door locks provided by Lasermet (electric door strikes or maglocks). These will prevent access to the room while the laser is on while always allowing people to enter or leave the room in the event of a power loss. In order to ensure that people can always enter or leave the room in the event of an emergency it will be necessary to put an emergency stop or break glass switch near each door. If in doubt call Lasermet technical help.

The door should be fitted with interlock switches (see section 6.2) so that the laser is disabled if a door is opened using the break glass switch.

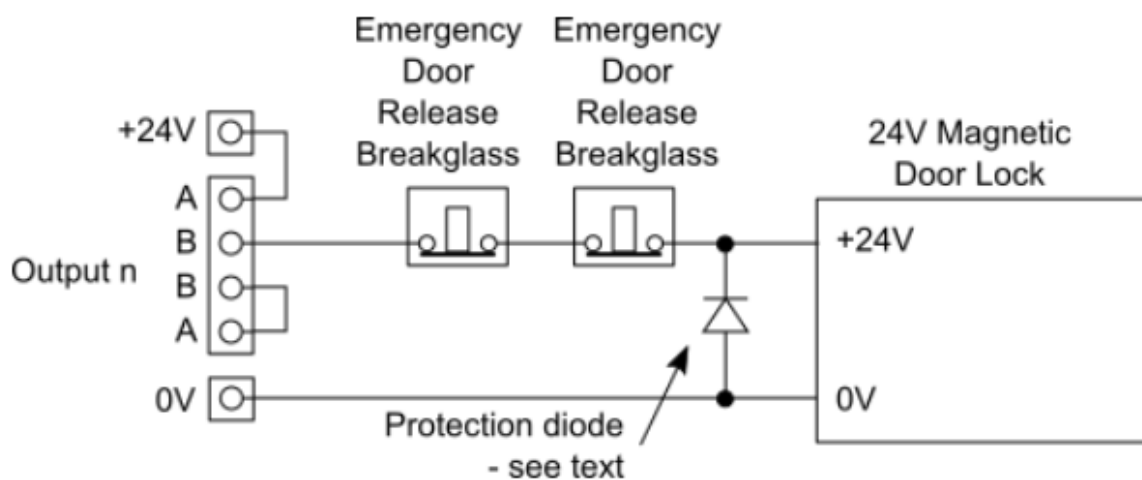

Note that several maglocks can be wired in parallel from the same ICS-7-OEM output provided the 4A maximum rating of the contact is not exceeded.

Some locks can be configured for 12V or 24V supply. They should be set for 24V operation and run off the 24V supply to reduce the current consumption to 0.25A per lock. To set the Maglock for 24V operation, open the terminal access cover on the lock. Remove the two black links from the circuit board and refit one of them across the middle two pins. Park the spare link with one side on one of the empty end pins so it is not lost. If in doubt, refer to the instructions supplied with the maglock.

In all cases a diode rated at 1A 50V or more must be wired directly across the terminals of each door lock. Lasernet's Maglocks usually have the diode fitted as standard, in which case it is essential that the supply is connected the right way round.

7 Expansion Boards

The ICS-7-OEM can be connected to one or more Lasernet Interlock Expansion Boards which provide extra functionality.

Boards which are currently available include:

- **Active Guarding Interface**

Lasernet's Active Guarding system is intended to be used with lasers which are potentially capable of damaging or burning through their enclosures. The enclosure is lined with replaceable active detection panels. If the laser burns through the panel it is shut down before it burns through the enclosure. The fail-safe Interface is available in the form of backplanes and plug-in interface boards and is able to monitor large enclosures. The ICS-7-OEM is able to automatically test the operation of the Active Guarding each time the system is armed.

- **Safety Logic Plus Interface**

Safety Logic Plus consists of a range of fail-safe logic function blocks which can be hardwired to realise a complex safety interlock. Each block is dual-channel crosschecked and does not use processors or software. Programming is achieved through hardwiring. This means obsolescence is minimised and the system is maintainable for a long service life. The Interface Board allows ICS-7-OEM to read the output of a Safety Logic Plus system whilst automatically testing it and providing fault protection.

- **Relay Expansion Card**

This module contains a number of uncommitted relays which may be connected as required to provide extra functionality or for interfacing to alarm, security or process control systems.

Other types of expansion boards are under development.

7.1 Installing Expansion Boards

Expansion boards are fitted into a separate module and connected to the ICS-7-OEM using a dedicated 15-way 'D' connector on the top of the unit.

Refer to the instructions supplied with the expansion unit for further details of how to fit expansion boards. Each expansion board has its own dedicated set of instructions showing how it is connected to external equipment and used.

If the expansion module is not used a termination plug must be fitted into the socket on the top of the ICS-7-OEM. The controller will not operate if the socket is left empty.

7.2 Use with Active Guarding

Power Switching and Self-test

The Active Guarding circuits are activated by a switched +24V supply from the ICS-7-OEM. This is normally switched on, allowing the status of the Active Guarding inputs to be seen. On closing the Arm inputs, the switched +24V supply is switched off momentarily to test the operation of the Active Guarding circuits, then switched back on if the test succeeds.

NOTE: This behaviour is different from that of the ICS-6-OEM.

Resetting faults on the Active Guarding

When a fault occurs on one of the Active Guarding inputs, it is temporarily latched to indicate which input has the problem. This shows a red light on the appropriate Active Guarding Interface input. When the problem has been rectified by a technician, the 'Expn Reset' button on the ICS-7-OEM should be pressed. This will briefly cycle the switched +24V power to the expansion board and the red light on the Active Guarding should be extinguished. If the red light remains, a fault still exists.

As an alternative to the 'Expn Reset' button, a contact closure may be made at the 'Expn Reset' input.

7.3 Expansion Board Fault Output

A volt-free contact output has been provided to signal a fault in the safety circuit connected to an expansion board. This may be used for panel indication or as an input to a PLC.

8 Mismatch Detector

The ICS-7-OEM trips out and disables the laser when either of its two safety circuits opens. If all the door interlock and emergency stop switches have two contacts, one in each safety loop, then it is normal for both safety circuits to open more or less simultaneously.

When the ICS-7-OEM Safety Circuit Mismatch Detection is enabled, if the second safety circuit does not open within a short time of the first (typically around 1 second), a mismatch is triggered and the Fault light illuminates on the front panel. It is then not possible to arm the system.

The ICS-7-OEM can also detect a mismatch between its two 'Output Monitor' circuits. If for example these terminals are being used to monitor a pair of power contactors, should one of the contactors become welded 'on' a mismatch will be indicated and the system will be locked out until the contactor is repaired and the ICS-7-OEM is reset.

Safety Circuit Mismatch Detection can only be used if all inputs to the ICS-7-OEM are dual channel. This includes all the door contacts and emergency stop buttons. If any input only operates one channel, then a mismatch will inevitably occur and the mismatch detector will be triggered. In the event that it is not possible for all of the inputs to be dual channel, the mismatch detector must be disabled as described later in this section. Note that the use of a single channel safety contact and the disabling of the mismatch detector will reduce the achievable safety performance level of the system.

8.1 Configurable Options for Safety Circuit Mismatch Events

Mismatch Event Behaviour

In the event of a mismatch being detected either of the following two actions are available depending on the option switch settings:

- a) Lock out, preventing further use, unless the system is reset by switching it off and on again;
- b) Lock out, preventing further use, unless the system is attended to by a qualified technician.

Option a) is suitable for mission-critical applications where the inability to use the laser would be costly or inconvenient. Having detected and indicated that there is a fault it allows the system to be reset to operate on the one good safety circuit provided the faulty circuit has been closed. The need to manually reset the system before it can be used provides a clear indication to operators that there is a problem that needs to be addressed at the earliest opportunity and that other risk limitation steps may be required in the interim. An example might be to secure the affected door out of use until it can be repaired.

Option b) is the lowest risk option, as once a safety circuit fault has been detected the system cannot be used. The ICS-7-OEM can only be reset by opening the cabinet in which it is mounted and operating the Fault Reset button. Procedures should indicate that this is only carried out by suitably trained technicians once the fault has been repaired.

By default, the mismatch detector is factory set to be enabled in option 'a' above.

Mismatch Detection Settings

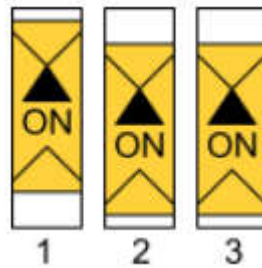

The Safety Circuit Mismatch Detection behaviour is set by the option switch on the right-hand side of the Emergency Stop input terminals. The options are described below.

Option	On	Off
1	Mismatch fault is automatically reset on cycling the 24V power. Power must be turned off for at least 10 seconds.	Mismatch fault must be reset by pressing the Fault Reset button or by a momentary contact closure at the Fault Reset input
2	Mismatch detection is disabled, for use with single-channel systems	Mismatch detection works normally
3	Mismatch detection on the Output Monitor input is disabled, but still operates on safety circuits	Mismatch detection works on safety circuits and the Output Monitor input

Pre-check Mismatch Detection and Safety Logic Plus

Safety relays used on expansion cards are also monitored for mismatch, so should any of these relays become stuck a mismatch is signalled. The Safety Logic Plus interface card generates a mismatch event during its start-up sequence, so if this expansion card is being used the pre-check mismatch detection must be disabled by setting Option 3 to On. Mismatch detection of the safety circuits is still provided in this mode.

8.2 Clearing a Mismatch Fault Indication

In all cases the fact that a mismatch fault has been indicated warns users that the safety of the system may be compromised. Site-specific instructions should indicate the actions to be taken by users in such an event.

If the auto reset option has been selected, the system may be temporarily cleared by turning the power supply off, waiting for ten seconds, then turning it back on again. In this case the system should be attended to by a suitably qualified technician to identify and repair the fault at the earliest opportunity as a fault has been identified and the system may cease to provide protection without further warning.

If the ICS-7-OEM has been configured to permanently lock out, it can only be reset by pressing the Fault Reset button. This should only be undertaken by suitably qualified technicians once the fault has been identified and repaired as otherwise the unit will just lock out again.

8.3 Mismatch Detector Remote Test and Reset

Terminals are provided that allow for remote testing and resetting of the mismatch detector if desired. For example, a key-operated switch could be connected to the terminals so that when it is set one way it tests the mismatch detector, and when set the other way resets it. The key is then returned to the mid position and removed to allow normal operation to resume.

The 'test' switch should have a contact which is normally closed, and which opens to perform the test. The 'reset' switch should have a contact which closes to reset the detector.

If the test function is not used a wire link must be fitted across the 'Test' terminals.

Contact Lasernet or your local distributor for assistance if you wish to use these features.

9 LED Indicators

Input LEDs A and B

Two LED's are provided for each of the six Interlock Inputs and the Emergency Stop Input. Each pair refers to an interlock switch or group of switches, depending on how the system has been wired up.

For each Interlock, a pair of yellow LEDs indicate that the interlock is open. If the contact is not used and a wire link has been fitted, the corresponding LED will not illuminate.

If both 'A' and 'B' contacts are fitted and it is observed that one LED is on and the other off, this indicates a fault which will be detected by the mismatch detector if it is enabled. In this event operation of the unit will be inhibited. Please see the 'Mismatch Detector' section.

'Safety Loop Complete' A and B

These LED's will light in green when both safety circuits are complete.

The system will not arm if either or both LED's are unlit. This may be due to any of the following:

- A door interlock switch is open, indicated by the 'Input' lights on the front panel.
- The emergency stop switch (if present) is activated, indicated by the 'E Stop' lights on the front panel. Reset the switch to enable the system.
- The expansion board, if fitted, is not ready, or the termination plug has not been fitted.
- The safety circuit is faulty.

'Arm' A and B

The Arm indicators will illuminate blue when external contacts have closed in an attempt to arm the controller. The controller will not arm if only one channel is closed, indicated by only one light being illuminated.

'Prearm OK' A and B

The Prearm OK indicators will illuminate green if the pre-check circuits are closed. The controller will not arm if the pre-check circuits are open. This may be for any of the following reasons:

- An LS-20 shutter is missing or not closed, or a dummy plug has not been fitted to an empty LS-20 socket.
- There is a problem associated with an expansion board, if fitted.
- There is a faulty external relay or contactor, if they are fitted.
- If the laser has 'laser safe' proving contacts (see section 6.4.3), the laser is not detected in the safe condition or is unplugged.
- The Output Monitor terminals have not had wire links fitted (if the terminals are unused). The two 'A' terminals should have one link across them, and a second link for the two 'B' terminals.

'Mismatch Fault' LED

If the system is wired as a fully dual-channel system, the Mismatch Detector is usually enabled as described in section 8.

The ICS-7-OEM continually monitors both safety circuits. If a mismatch occurs that lasts for more than about a second, the Mismatch Detector is triggered, which disables the system and illuminates a red 'Fault' light on the front panel.

The Mismatch Detector also monitors the internal relays of the controller and the safety proving contacts of external equipment such as dual shutters, contactors, etc.

Site-specific procedures may be applicable in such an event, which cover actions to be taken to determine the cause of the fault, to have it rectified and to restore the system to operation. There may also be procedures to allow operation in degraded mode until normal operation can be restored.

Section 8 describes the mismatch detector and how it is reset.

'System Armed' LEDs

When the 'Safety Loop Complete' LED's are lit and the external Arm contacts have been closed, the 'System Armed' LED's will light orange to warn that the ICS-7-OEM has enabled the laser. If the 'Safety Loop Complete' LED's are illuminated but the 'System Armed' LED's do not illuminate when the external Arm contacts are closed, this could indicate that the internal checking circuitry of the ICS-7-OEM has detected a fault condition.

'Doors Closed' LED

The 'Doors Closed' LED is situated next to the 'Doors Closed' status output and illuminates in green to indicate that all the door interlock inputs are closed. This includes all safety switches connected to inputs 1-6 but not the Emergency Stop.

Power Supply LEDs

Main supply points

Green '24V On' and 'Expn On' LEDs indicate that the main 24V power supply and the 24V switched power supply to the expansion board are on. If the '24V On' LED is not illuminated, check the power supply connection and the main power supply fuse (4A T). If the 'Expn On' LED is not illuminated, check the expansion supply fuse (3.15A T).

Power supply trips

In the ICS-7-OEM, the internal fuses for the safety inputs have been replaced with fast-acting electronic trips. These are indicated by LEDs in the Power Supplies block. They are normally illuminated in green. If a short circuit occurs between the A and B safety inputs, which have opposite polarity, the 'Loop A' or 'Loop B' LED will extinguish. This may be accompanied by a mismatch fault. When the short circuit has been rectified and any mismatch fault cleared, the power supply trips can be cleared by cycling the main +24V power supply. Another trip LED, 'Prearm', indicates an internal supply. If this LED is not lit, there is probably an internal fault in the unit.

'Expn Fault' LEDs

When the safety loop connection to the expansion board is broken, this LED is illuminated in yellow. This may occur if an expansion board has detected a fault, or if the expansion socket is open and no termination plug has been fitted.

10 Operation

Once correctly wired, the ICS-7-OEM is extremely easy to use. The following instructions cover the most common arrangements. For more complex customer-specific systems, additional procedures may apply.

10.1 Starting Up

- 1) Apply 24V power to the controller.
- 2) Close all interlocked doors. The 'Input' LED's on the front panel will indicate yellow if the corresponding door is not closed.
- 3) Check any Emergency Stop buttons are released- if any have been pressed the 'E Stop' lights will illuminate yellow.
- 4) The 'Safety Loop Complete' and Pre-Arm Ready LED's will light green.
- 5) When you are ready to operate the laser, close the external contacts connected to the Arm terminals. If all is well the amber 'System Armed' lights will be illuminated on the front panel of the unit.

N.B. Be aware that this action restores power to the shutters or the laser, and may result in accessible laser beams, depending on your system set up. This button should only be pressed when everyone is ready and the necessary safety precautions have been taken e.g. protective eyewear etc.

If an attempt to arm the system is made while an input is open, the controller will not arm even if the input is then closed. The external 'Arm' contacts must be opened, and a new arm attempt made.

10.2 Resuming Operation after an Interlock Switch has been opened

When any interlocked door is opened or the emergency stop button is activated, the ICS-7-OEM will cut the power to the laser or the shutters and the 'System Armed' lights will be extinguished. To resume laser operation:

- 1) Open the Arm contacts.
- 2) Close all interlocked doors (where necessary). Note LED state on front panel.
- 3) Reset the emergency stop button (where necessary).
- 4) When ready to restart, close the external Arm contacts.

N.B. Be aware that this action restores power to the shutters or the laser, and may result in accessible laser beams, depending on your system set up. This action should only be taken when everyone is ready and the necessary safety precautions have been taken e.g. protective eyewear etc.

11 Fuses

The ICS-7-OEM has two protection fuses which might blow if there is a fault or wiring error. Both are indicated on the label (see fig. 1) and have removable plastic covers for protection. Their ratings are as follows:

Main 24V power supply fuse	4A T 20 x 5mm
24V Expansion power fuse	3.15A T 20 x 5mm

Electronic trips are used to protect the power supplies to the A and B safety loops. If the A and B safety loops are crossed over, one or both of these circuits will trip. When the fault is cleared, the trips may be reset by cycling the +24V power to the unit.

12 Specifications

Safety Performance	Upto PL'e' to EN ISO 13849-1:2008 see section 3.
Shutdown Time	17ms typical. Measured from opening of safety circuits to opening of interlock operator contacts.
Maximum Safety	220Ω at 24V supply voltage
Loop Resistance	140Ω at 21.5V supply voltage
Supply Voltage	24V DC (21.5 – 26.5V)
Power Consumption	11W typical (ICS-7-OEM only)
No. of Output Contacts	7 dual channel (NO) + 1 dual channel (NC)
Output Contact Rating	4A 50VDC resistive load
Ingress Protection	IP20
Operating Conditions	0° to 55°C, 0% - 95% relative humidity non-condensing
Size	278mm wide X 105mm high X 58mm over DIN rail
Weight	0.8kg

Dimensions are approximate. Values given as 'typical' are average values measured across a number of samples and are not guaranteed. Lasermet reserve the right to alter any specification without prior notice.

13 Warranty

Lasermet provide a 12-month warranty for defects in materials and manufacture, from the date of installation or delivery. Installations completed by Lasermet are covered against defects in workmanship for 12 months.

Damage or defects caused by other factors are not covered. For example, industrial contamination, incorrect cleaning, storm damage. Consequential loss is not covered under warranty. Compensation for indirect or direct loss or damage is expressly excluded. Rectification of the defects or a replacement does not initiate a new warranty period.

For all deliveries, payments and other legal transactions, English law takes precedence for any litigation.

14 Contact Details

Lasermet provide a full range of laser interlock equipment including interlock switches, illuminated warning signs, laser shutters, entry keypads with built-in fail-safe override timer, door locks, external power supplies etc. which can be interconnected to provide a complete system. We also supply equipment and consultancy covering all aspects of laser safety. Full support, design, and installation is available from Lasermet, please contact us for any queries.

For sales and technical support:

Lasermet Ltd.

Lasermet House,
137 Hankinson Road,
Bournemouth
BH9 1HR
United Kingdom.

Tel: +44 (0) 1202 770740

Fax: +44 (0) 1202 770730

Email: sales@lasermet.com

Website: www.lasermet.com

Lasermet Inc.

10N Martingale Road, Suite 400,
Schaumburg, Illinois 60173
United States.

Tel: 847 466 1475

Email: usa@lasermet.com

Website: www.lasermet.com